

ET250R2-3D

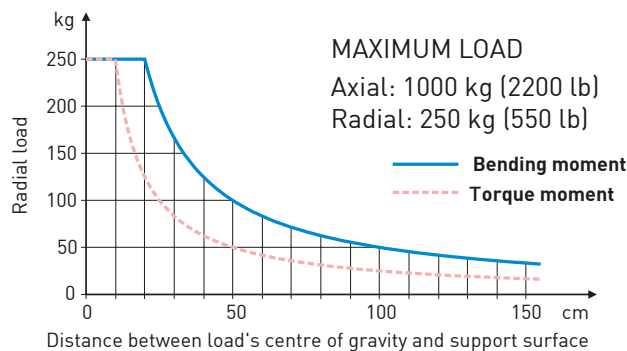

- > Ideal for loads up to 1000 kg (2200 lb)
- > Mammoth torque capability
- > Total integration with various measurement software
- > Control Libraries for Matlab and Python available
- > Ability to automate repetitive measurements, enabling high-precision orientation-dependent tests
- > Superlative engineering to provide a long working life
- > Onboard control electronics

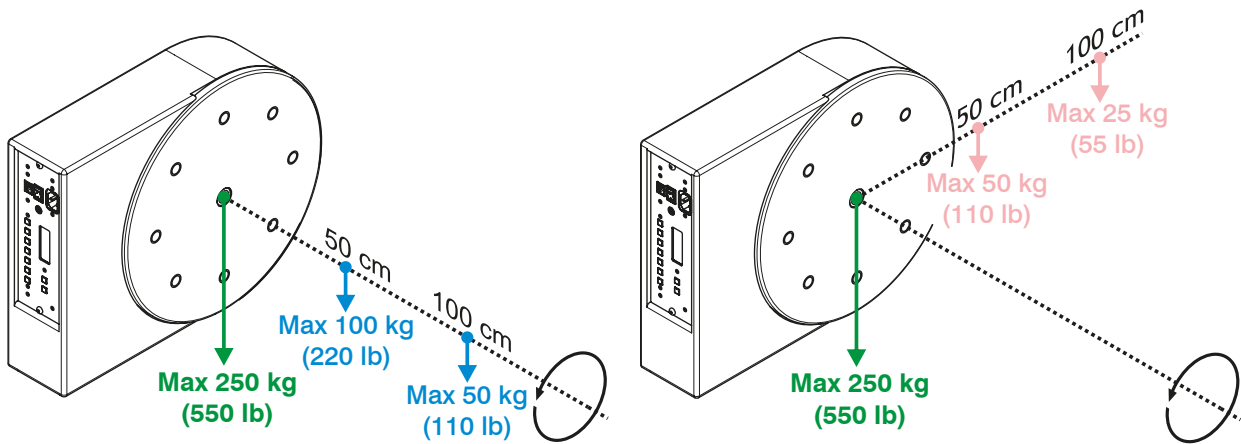

ROTATION DATA

Mounting Condition	Horizontal, Vertical, Upside-down
Drive System	Irreversible worm gear
Direction	Clockwise or counter-clockwise
Max speed	0.35 RPM
Max Axial Load (only in compression)	1000 kg (2200 lb)
Max Axial Load (upside-down)	200 kg (440 lb)
Max Radial Load	250 kg (550 lb)
Max Torque	25 kgm (250 Nm)
Max Bending Moment	50 kgm (500 Nm)
Resolution	0.5°
Acceleration and Max Speed	Microprocessor-controlled

CONTROL

Local	TTL pulse input and output
Remote	Standard Ethernet Protocol

PHYSICAL

Chassis Material	Scratch-Resistant Painted Wood
Rotating Disc Diameter	350 mm - 13 3/4"
Top Mounting Holes	8 x M8 on 244 mm Diameter + 1 x M20
Bottom Mounting Holes	8 x M8 on 244 mm Diameter (on chassis) + 1 x M20 (for counterweight use only)
Height	107 mm - 4 1/2"
Width	350 mm - 13 3/4"
Depth	455 mm - 17 7/8"
Weight	14.3 kg (31.5 lb)
Colour	Black

POWER REQUIREMENTS

Mains supply	90/250 V AC - 50/60 Hz
Room Temperature	From -5° to 45° C

